

PLAN VIEW

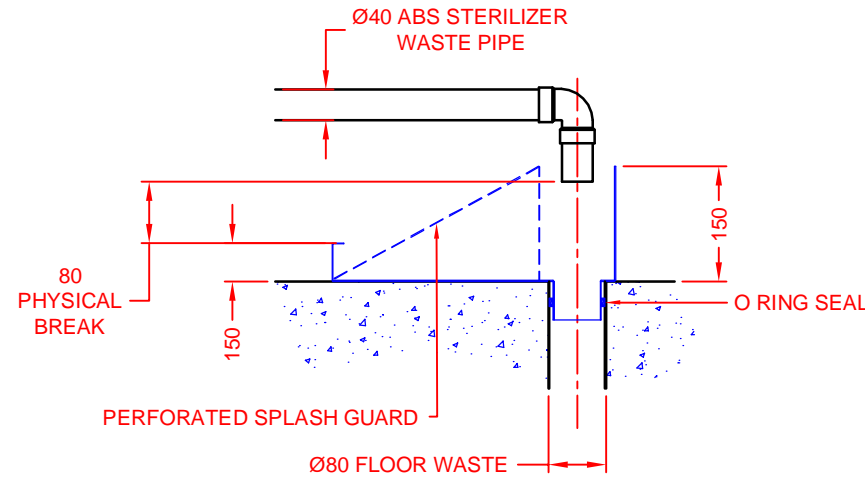

TYPICAL FLOOR WASTE & TUNDISH DETAIL
NOTE! TUNDISH SUPPLIED BY
ATHERTON

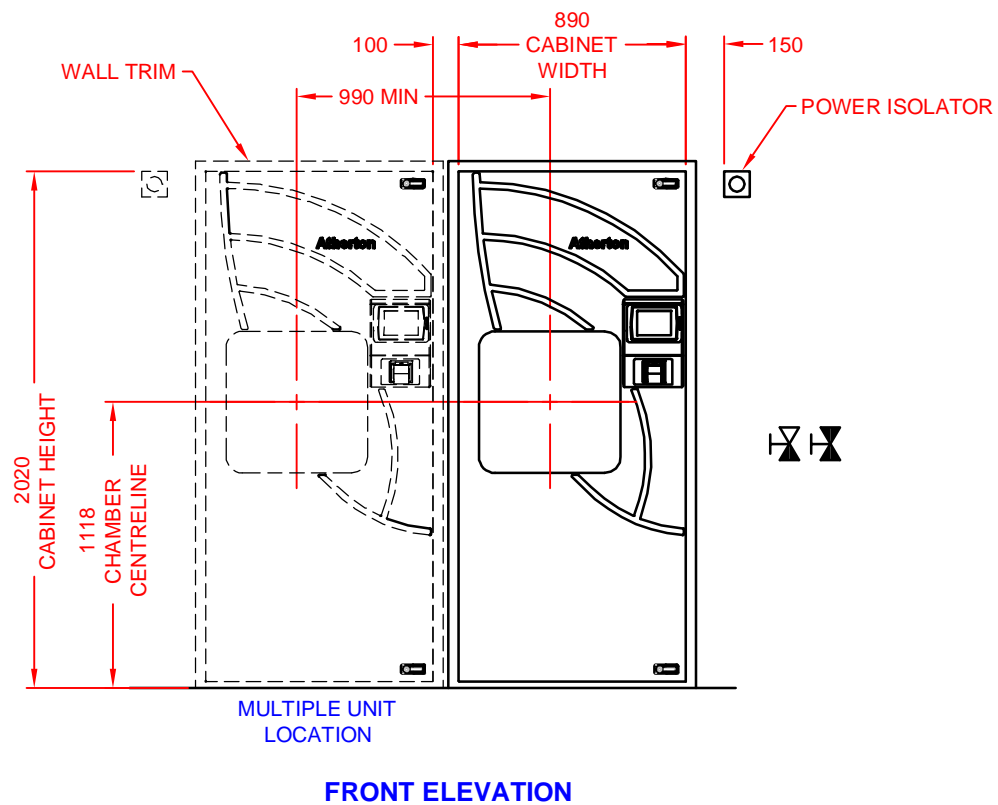

FRONT ELEVATION

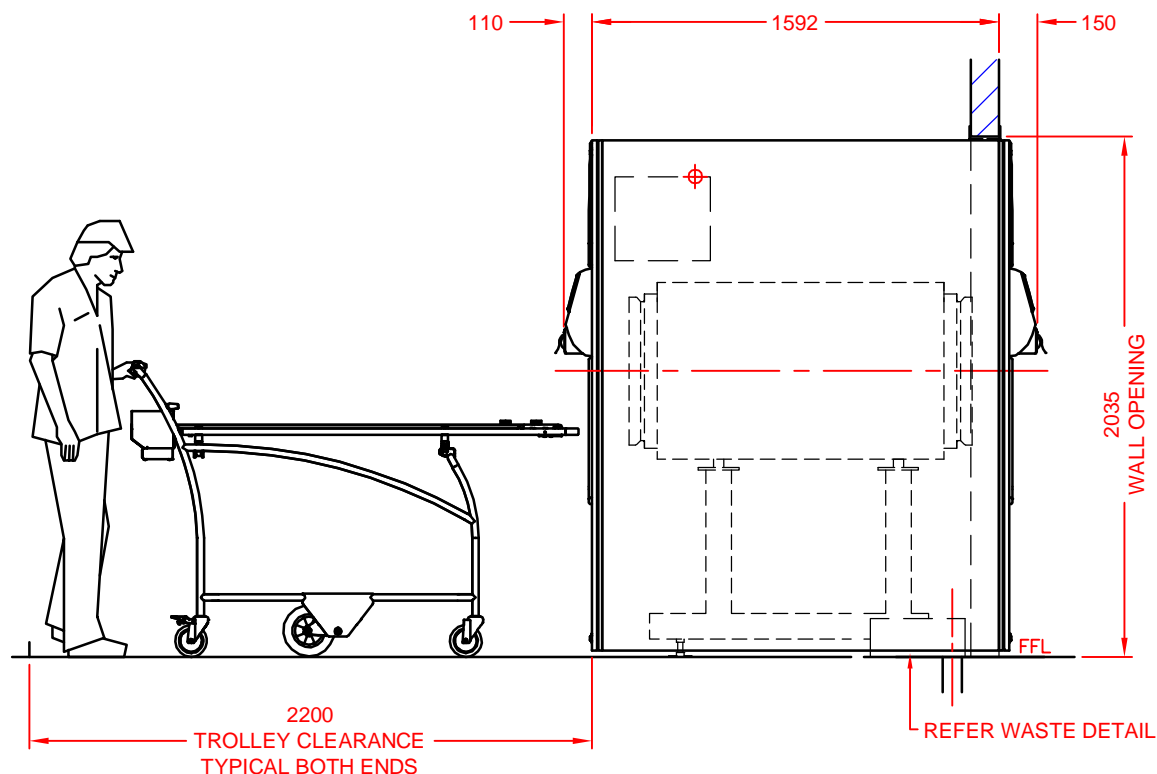

SIDE ELEVATION

SERVICE REQUIREMENTS BY OTHERS

COLD WATER - SUPPLY TO BE CONSTANTLY BETWEEN 200 & 500 KPA, MAXIMUM TEMPERATURE 25°C, TREATED IF OVER 2 PPM (0.02MMOL/L) HARDNESS, CHLORIDE FREE, COMPLETE WITH 15MM ISOLATING VALVE & BACK FLOW PREVENTION TO AS 3500.1. AVERAGE WATER CONSUMPTION IS APPROXIMATELY 11 LITRES/MIN WITH A MAXIMUM OF 15 LITRES/MIN FOR 3 MINUTES PER CYCLE.

TREATED WATER - WHERE WATER QUALITY DOES NOT MEET AS 1410 TABLE 1, TREATED WATER MUST BE SUPPLIED, COMPLETE WITH 15MM ISOLATING VALVE & BACK FLOW PREVENTION TO AS 3500.1. INITIAL FILL REQUIREMENTS: 28 LITRES. AVERAGE WATER CONSUMPTION IS APPROXIMATELY 0.2 LITRES/MIN WITH A MAXIMUM OF 5 LITRES/MIN FOR 3 MINUTES PER CYCLE.

WASTE - Ø80MM TO SEWER IN COMPLIANCE WITH AS 3500.2. AVERAGE WASTE OUTLET TEMPERATURE 50°C WITH A MAXIMUM OF 100°C SHORT TERM. ATHERTON SUPPLIED TUNDISH TO BE LOCATED OVER WASTE POINT. Ø40 STERILIZER DISCHARGE ABS PIPE MUST DISCHARGE INTO TUNDISH WITH 80MM PHYSICAL AIR BREAK.

POWER - TO AS 3000. 3 PHASE, NEUTRAL & EARTH, 50 AMPS PER PHASE. DIRECT CONNECTION TO UNIT. ATHERTON RECOMMENDS "FEDERAL WR363" SWITCH.

VENTILATION - ATHERTON RECOMMENDS VENTILATION OF THE STERILIZER ROOM FOR THE REMOVAL OF HEAT.

FLOOR WASTE - ATHERTON RECOMMENDS THE INSTALLATION OF A CORRECTLY DRAINED FLOOR WASTE TO HELP REDUCE POTENTIAL DAMAGE IN CASE OF A MAJOR STEAM OR WATER LEAK.

PRODUCT CODE & SPECIFICATIONS

CECD5513 - CYBER SERIES JERBOA, STEAM GENERATOR, CABINET, DOUBLE DOOR STERILIZER.
CHAMBER DIMENSION: 535 x 535 x 1340MM DEEP.
HEAT LOSS FRONT OF WALL AT 21°C : 750 WATTS.
HEAT LOSS FROM CABINET AT 21°C : 2550 WATTS.
OPERATING WEIGHT (CHAMBER FILLED WITH WATER) : 1300 KG
PACKED WEIGHT : 1200 KG
STRIP DOWN SIZE : 720 WIDE x 1500 HIGH x 1520MM LONG

GENERAL NOTES

ALL DIMENSIONS ARE IN MM.
GENERAL TOLERANCE ON BUILDING ±5MM.
ALL SERVICE SPECIFICATIONS ARE DYNAMIC.
SERVICES AND BUILDING REQUIREMENTS ARE TO BE SUPPLIED BY THE CLIENT UNLESS OTHERWISE SPECIFIED.

Atherton

STERILIZER INSTALLATION DETAILS

CECD5513 CYBER SERIES JERBOA STERILIZER

CLIENT APPROVAL

PROJECT.....
APPROVED BY
(PRINT NAME).....
SIGNED..... DATE.....

SPECIAL REQUIREMENTS

IF DRAWING IS NOT RETURNED WITHIN 30 DAYS, ATHERTON WILL ASSUME THAT ALL SERVICES & SPACE REQUIREMENTS HAVE BEEN PROVIDED. ATHERTON TAKES NO RESPONSIBILITY FOR DELAYS, COSTS OR DAMAGE TO EQUIPMENT IF PURCHASER DOES NOT SUPPLY SERVICES AS DETAILED IN THIS DOCUMENT AND WARRANTY COVER MAY BE VOID.

DRAWN. P.L.G.	DATE. 09/11/2011	APPROVED.
DOCUMENT NO.	REV NO.	SCALE
025328	0	1:30
SHEET SIZE A3	DATE.	R.OLIVER
		14/11/2011